

User	Component	Qty	UM	Description
0010	021929-20	1.00	EA	HLDR,PQAS1/2",SCR,W/O HOSE
0020	02041-09	1.00	EA	HOSE,AIR,TYPE 1 - 20" W/CPLR

REVISIONS			
REV.	ERN	DATE	CHK'D BY
-	4499	5/12/2020	RELSD

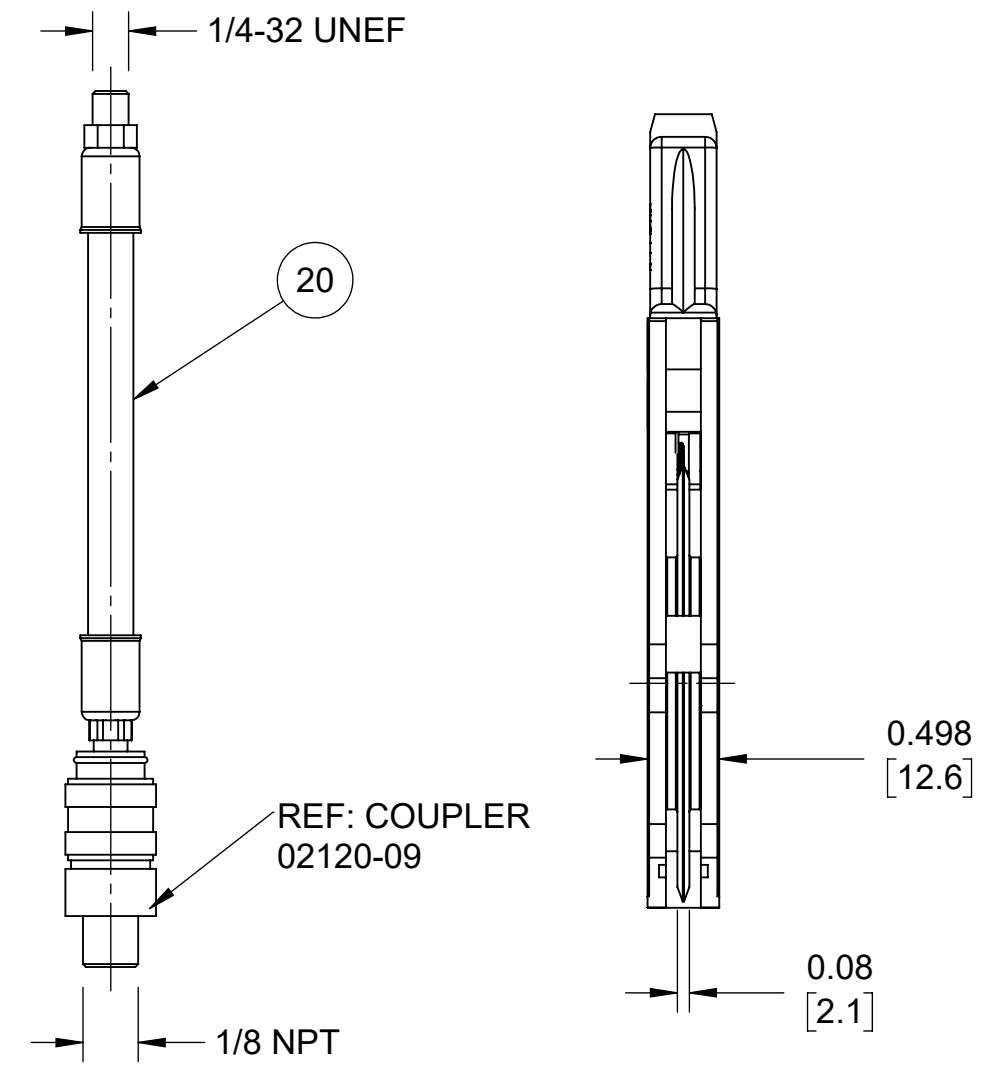
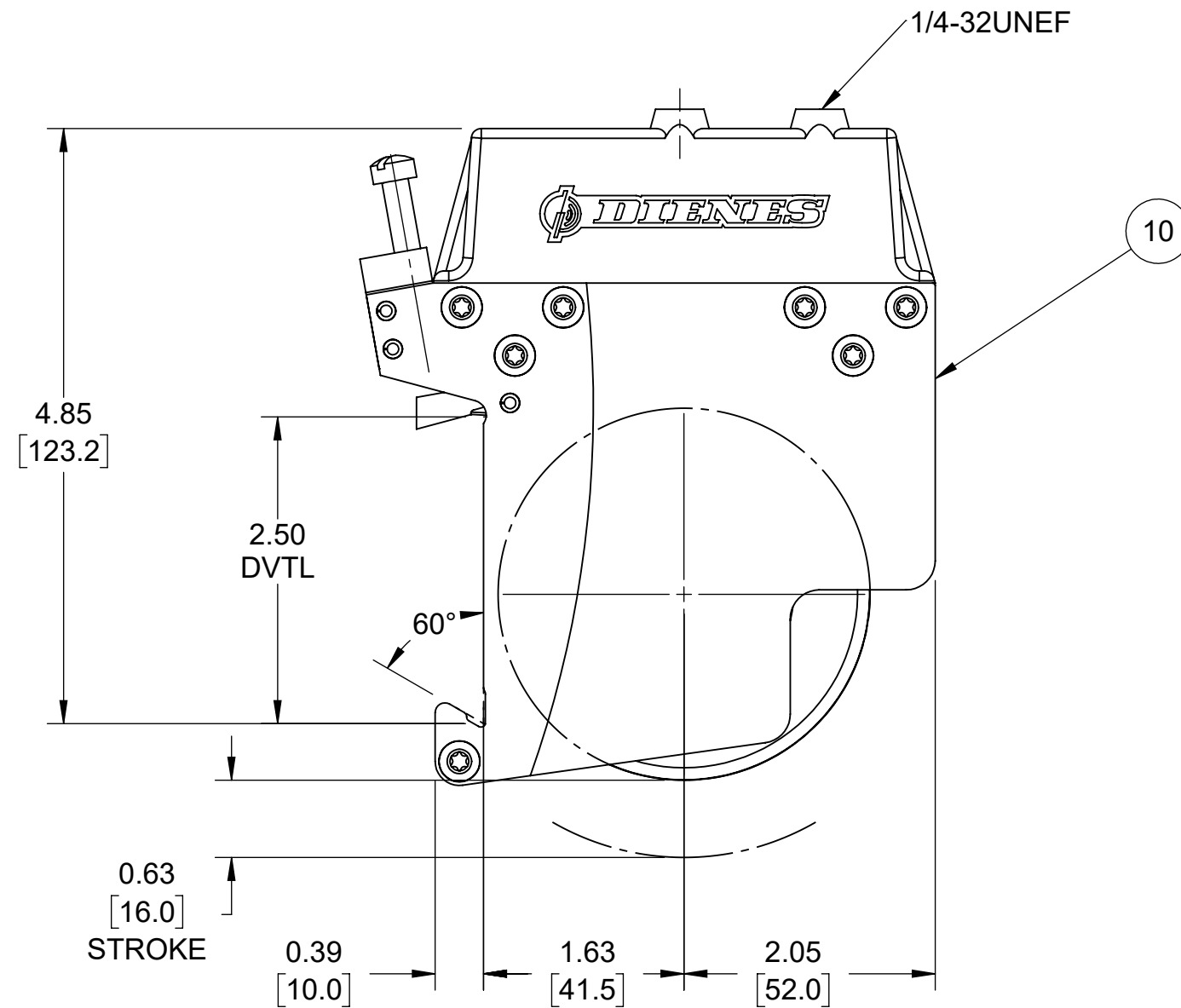
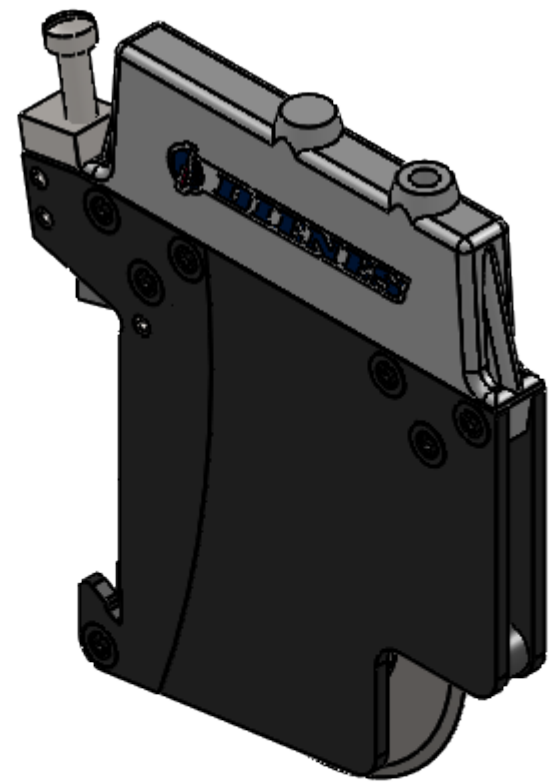

NOTES:

1. MATERIAL: SEE BILL OF MATERIAL.
2. THIS HOLDER IS STANDARD CONFIGURATION.
3. USE FIXTURE TO ENSURE HOLDER IS ASSEMBLED SQUARE, IF APPLICABLE
4. TEST HOLDER FOR STROKE & PNEUMATIC LEAKS.
5. APPROX. WEIGHT: 1.67 LBS
6. REF DW DWG 244A081C01001.

This document is the property of
Dienes Corporation
 It may contain proprietary information
 DO NOT USE FOR PURPOSES
 OTHER THAN THOSE INTENDED

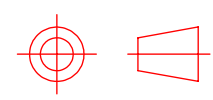
 US PROJECTION		DIENES CORPORATION Spencer Massachusetts	
REFERENCE METRIC DATA		HLDR,PQAS1/2",STD,SCR FIX	
Unless Otherwise Noted Dimensions Are In Inches Tolerances Unless Noted: .XXX ±.005 .XX ±.010 FRACT. ±.015 ANGLE ±1/2° Finish Unless Noted: <input checked="" type="checkbox"/> 125		Drawn by: BGB Date: 05/12/2020 Checked by: BB Date: 05/12/2020 Scale: 3:4	Drawing Number C02023-01 Rev. -
O.D.		Sheet 1 of 2	
I.D.		REF DWG: 22300	
THK.		For Internal DIENES CORPORATION Use Only	

PQAS 1/2" Screw Clamp Score Cut Holder

Dienes No. 02023-01

ITEM NO.	PART NUMBER	DESCRIPTION	QTY.
1	02032-09	CYLINDER,PRESSURE - PQAS	1
2	02769	PQAS LH Sideplate (Thd holes)	1
3	02768	PQAS RH Sideplate (C'bore'd holes)	1
4	02034-09	PQAS 1/2" Knife Fork	1
5	02599	Intermediate Piece	2
6	02035-09	Bearing Pin	1
7	02254	Knf,Crushcut 793a - 52100	1
8	02033-09	Gasket,Bladder PQAS 1/2"	1
9	02037-09	PQAS 1/2-Clamp Arm	1
10	02036-09	PQAS Clamp Body	1
11	33686-0015	LOGO,DECAL	1
12	02777	PIN,SPRING M4x12	3
13	02038-09	Distance Ring	2
14	02676/02698	BRG,BALL,OPEN 8X22X6 or 6X19X6	1
15	02039-09	SPRING,PRESSURE	2
16	02041-09	HOSE,AIR,TYPE 1 - 20" W/CPLR	1
17	02125-09	SCR,FILLISTER HD,12-24X1.5 LG	1
18	02095-09	SCR,CAP,FL TORX HD,M4x12	7
19	412414-01	SPRG,RETURN,PQAS/PQDS	1
20	222158-10	CLAMP ASSY,1/2PQAS,(10-24 SCR)	1
21	02298-09	HOSE,AIR,TYPE 3, 20"W/CPLR	1

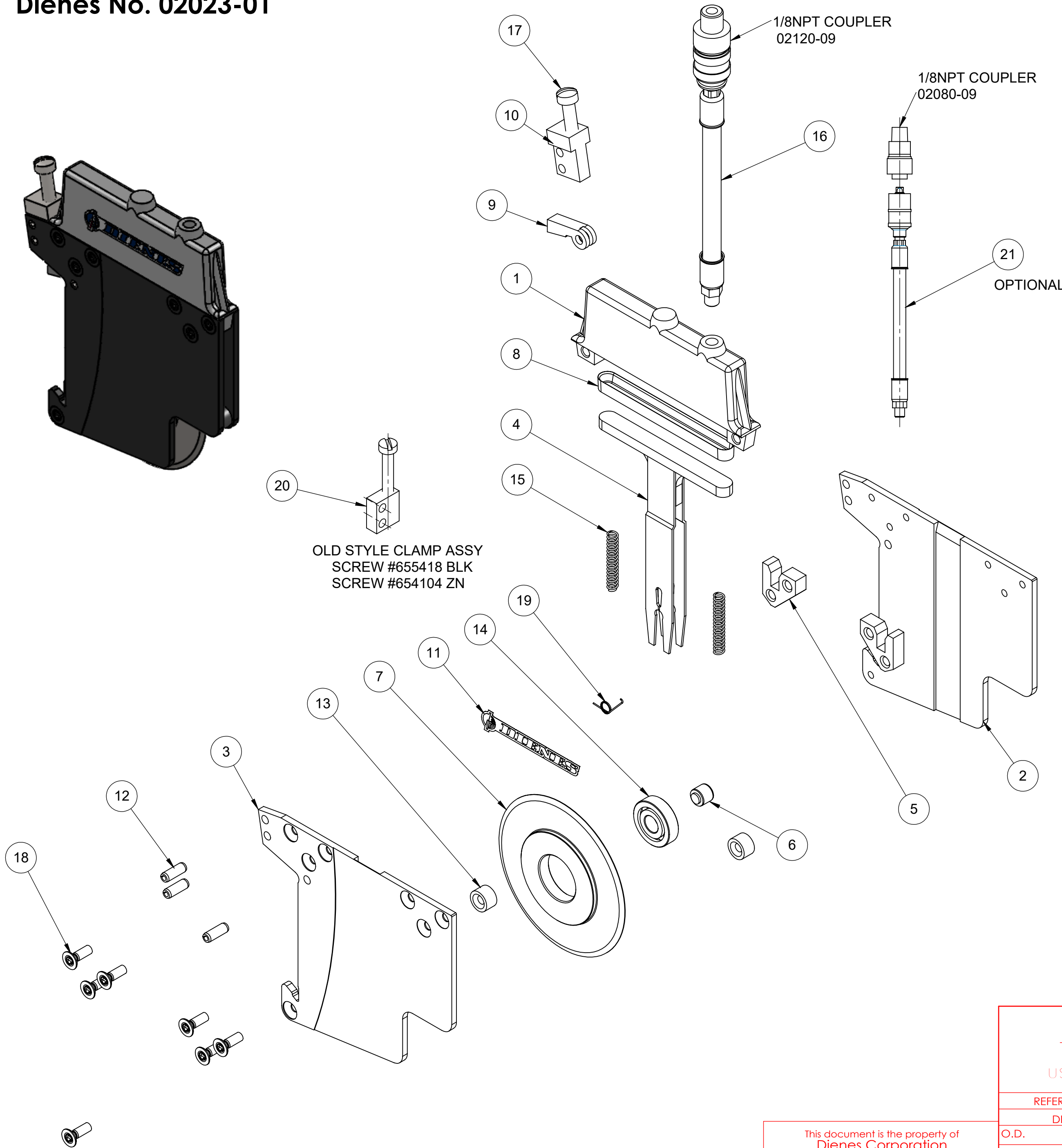

This document is the property of
Dienes Corporation
 It may contain proprietary information
 DO NOT USE FOR PURPOSES
 OTHER THAN THOSE INTENDED

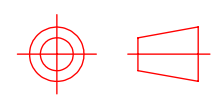
 US PROJECTION		DIENES CORPORATION <i>Spencer Massachusetts</i>	
HLDR,PQAS1/2",STD,SCR FIX		Drawn by: BGB Date: 05/12/2020	Checked by: BB Date: 05/12/2020
REFERENCE METRIC DATA		Unless Otherwise Noted Dimensions Are In Inches Tolerances Unless Noted: .XXX ±.005 .XX ±.010 FRACT. ±.015 ANGLE ±1/2° Finish Unless Noted: <input checked="" type="checkbox"/>	Scale: 3:4
DIM.	TOL.	DO NOT SCALE DRAWING	
O.D.		Drawing Number: C02023-01	
I.D.		Sheet 2 of 2	
THK.		Rev. -	
REF DWG:	22300	For Internal DIENES CORPORATION Use Only	