

REVISIONS			
REV.	ERN	DATE	CHK'D BY
-	4499	2/8/2022	RELSD

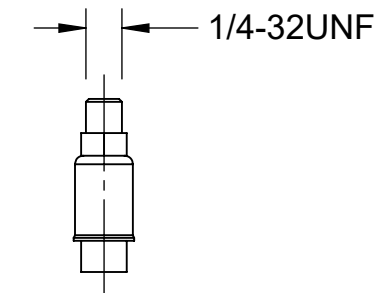

TYPE I HOSE

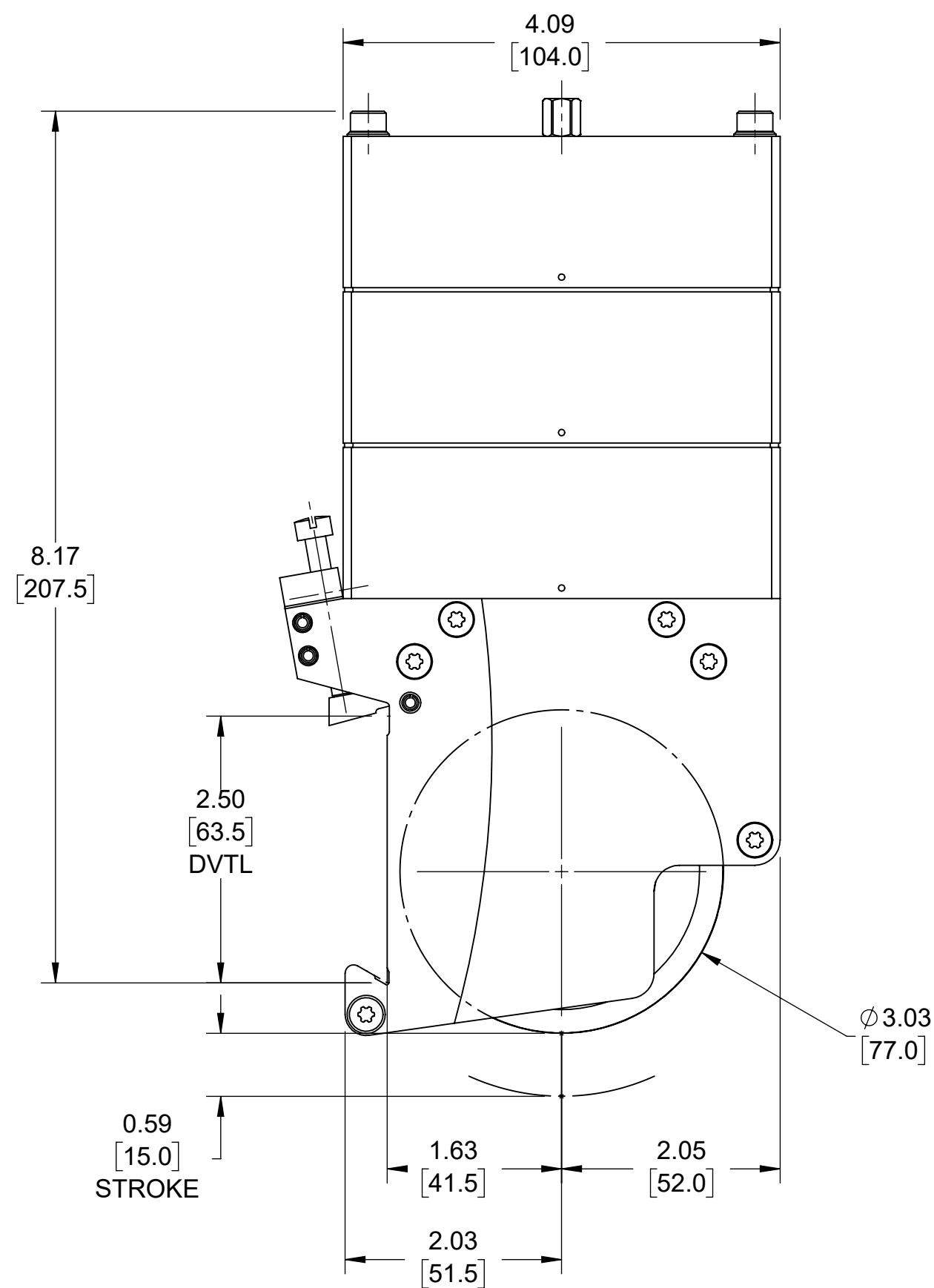
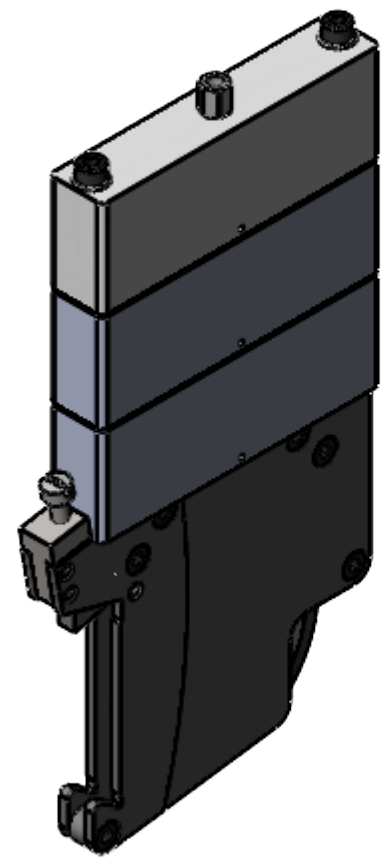
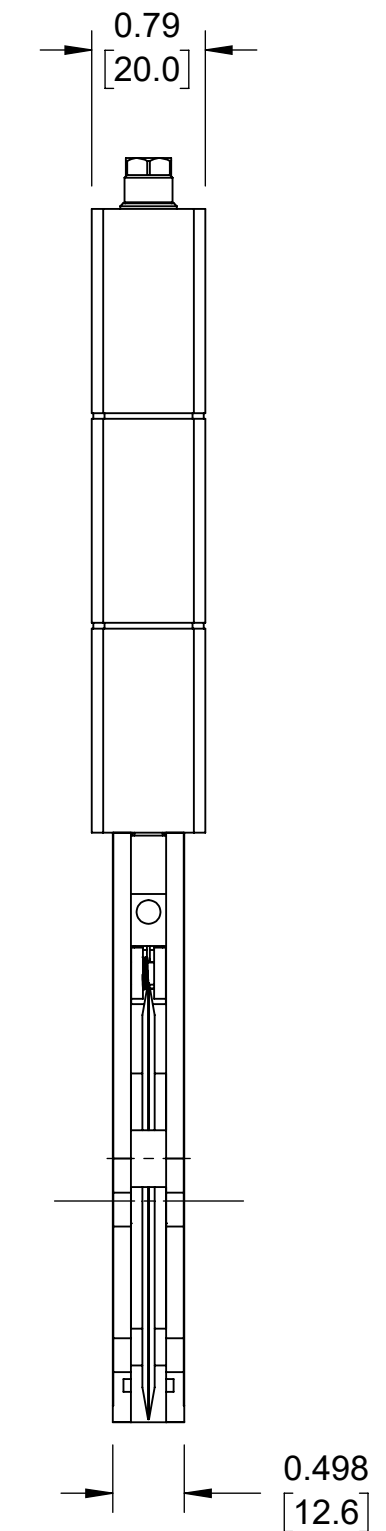
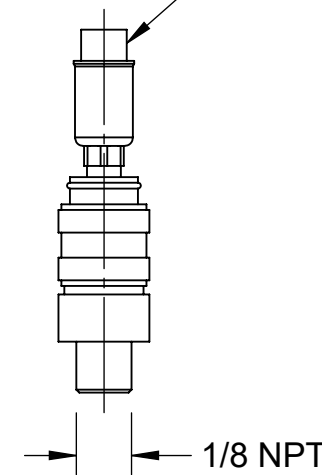

**NOTES:**

1. MATERIAL: REF DW DWG 244A208B01002.
2. THIS HOLDER IS STANDARD CONFIGURATION.
3. USE FIXTURE TO ENSURE HOLDER IS ASSEMBLED SQUARE, IF APPLICABLE
4. TEST HOLDER FOR STROKE & PNMEUMATIC LEAKS.
5. APPROX. WEIGHT: 3.885 LBS

This document is the property of  
Dienes Corporation  
It may contain proprietary information  
DO NOT USE FOR PURPOSES  
OTHER THAN THOSE INTENDED

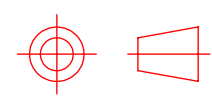
 <b>US PROJECTION</b>		<b>DIENES CORPORATION</b> <i>Spencer Massachusetts</i>	
<b>REFERENCE METRIC DATA</b>		<b>HLDR, PQA-MC3, 12/20mm</b>	
<small>Unless Otherwise Noted Dims in Inches</small>		<small>Drawn by:</small>	<b>BGB</b>
<small>Tolerances Unless Noted:</small> .XXXX ±.0005 .XXX ±.005 .XX ±.010 .X ±.015 ANGLE ±1/2° Finish Unless Noted: <input checked="" type="checkbox"/> 125		<small>Date:</small>	<b>02/08/2022</b>
<small>DO NOT SCALE DRAWING</small>		<small>Checked by:</small>	<b>BB</b>
<small>Sheet 1 of 2</small>		<small>Date:</small>	<b>02/08/2022</b>
<small>REF DWG: 02393</small>		<small>Scale:</small>	<b>3:4</b>
<small>DIM</small>		<small>Drawing Number</small>	<b>C02890</b>
<small>TOL</small>		<small>Rev.</small>	<b>-</b>
<small>O.D.</small>		<b>For Internal DIENES CORPORATION Use Only</b>	
<small>I.D.</small>			
<small>THK.</small>			

# PQD-MC3 12/20MM Score Cut Holder

## Dienes No. 02890

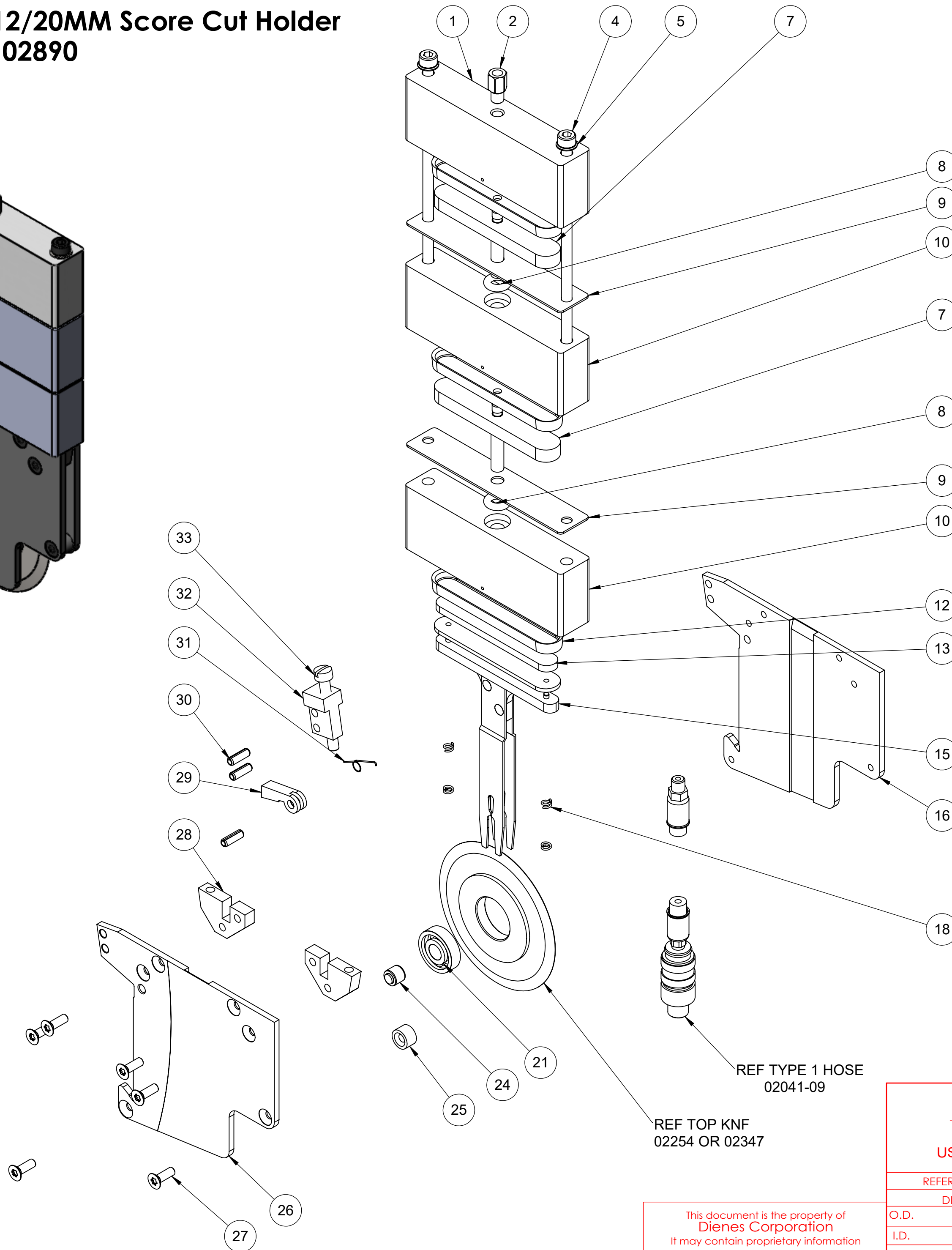
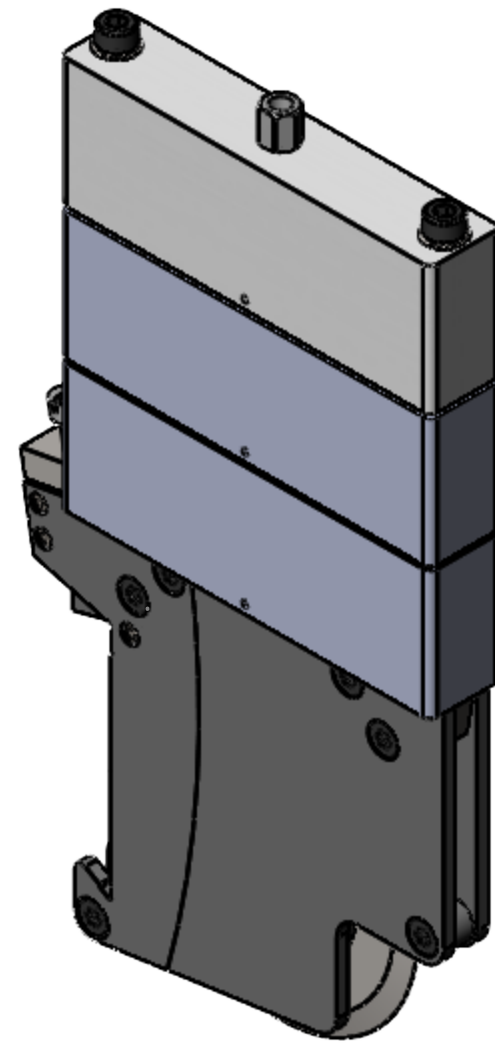

ITEM NO.	PART NUMBER	DESCRIPTION	QTY.
1	244B110563010	CYLINDER,PRESSURE,PQADF30	1
2	244B020417080	ADPT,NIPPLE,1/4-32M X M6F	1
4	613604	SCR,CAP,SOC HD,M5X120	2
5	615722	WASH,PLAIN,M5	2
7	244A215001001	PISTON - PQD-MC-3	2
8	021571	O-RING R6-3.5	2
9	021401	INTERMEDIATE PIECE	2
10	244B110564010	CYLINDER,PRESSURE,PQD-MC-3	2
12	244B090176010_1	GASKET,DF30	1
13	244B000678040	SHIM PLATE,PQAMC-3(3.7mm)	1
15	021229	KNIFE FORK,PQD MC3	1
16	244B120715010	SIDE PLATE-RH NO RESALE	1
18	021245	SPRG,COMP,5.0MMX0.75X35MM	2
21	02676	BRG,BALL,OPEN 8X22X6	1
24	02035-09	PIN,BRG,1/2" HLDR 22MM BRG	1
25	02038-09	RING,DISTANCE - PQAS 1/2"	2
26	244B120714010	SIDE PLATE-LH NO RESALE	1
27	02095-09	SCR,CAP,FL TORX HD,M4X12	6
28	244B040713020	BLOCK,INTERMEDIATE	2
29	02037-09	CLAMP ARM - PQAS 1/2"	1
30	02777	PIN,TENSION,M4X12	3
31	412414-01	SPRG,RETURN,PQAS/PQDS	1
32	02036-09	CLAMP,BODY PQAS 1/2"(12-24 SCR	1
33	02125-09	SCR,FILLISTER HD,12-24X1.5 LG	1
34			

REF TOP KNF  
02254 OR 02347

REF TYPE 1 HOSE  
02041-09

This document is the property of  
Dienes Corporation  
It may contain proprietary information  
DO NOT USE FOR PURPOSES  
OTHER THAN THOSE INTENDED

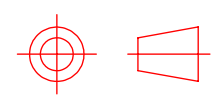
 <b>US PROJECTION</b>		<b>DIENES CORPORATION</b> <i>Spencer Massachusetts</i>	
<b>REFERENCE METRIC DATA</b>		<b>HLDR,PQA-MC3,12/20mm</b>	
<small>Unless Otherwise Noted Dims in Inches</small>		<small>Drawn by:</small>	<b>BGB</b>
<small>Tolerances Unless Noted:</small> .XXXX ±.0005 .XXX ±.005 .XX ±.010 FRACT: ±.015 ANGLE: ±1/2° Finish Unless Noted: <input checked="" type="checkbox"/> 125		<small>Date:</small>	<b>02/08/2022</b>
<small>DO NOT SCALE DRAWING</small>		<small>Checked by:</small>	<b>BB</b>
<small>Sheet 2 of 2</small>		<small>Date:</small>	<b>02/08/2022</b>
<small>Drawing Number</small>		<small>Scale:</small>	<b>3:4</b>
<small>REF DWG:</small>		<small>Drawing Number</small>	<b>C02890</b>
		<small>Rev.</small>	<b>-</b>
<small>For Internal DIENES CORPORATION Use Only</small>			