

REVISIONS			
REV.	ERN	DATE	CHK'D BY
-	4499	5/14/2020	RELSD

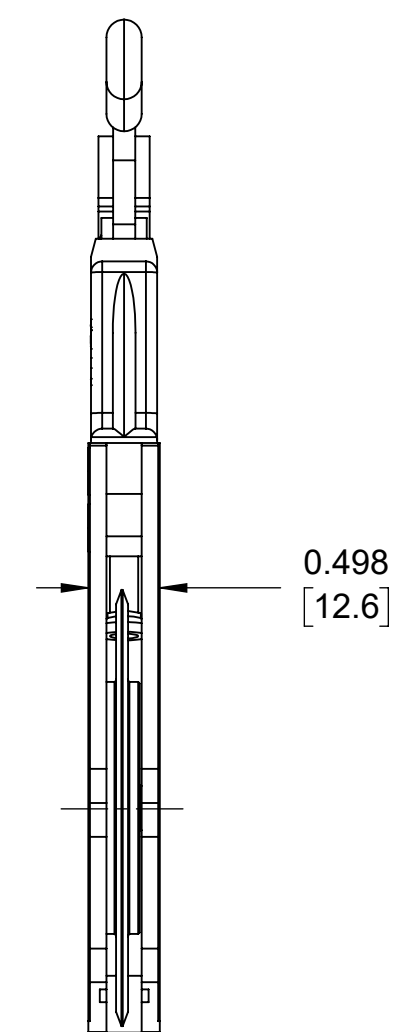
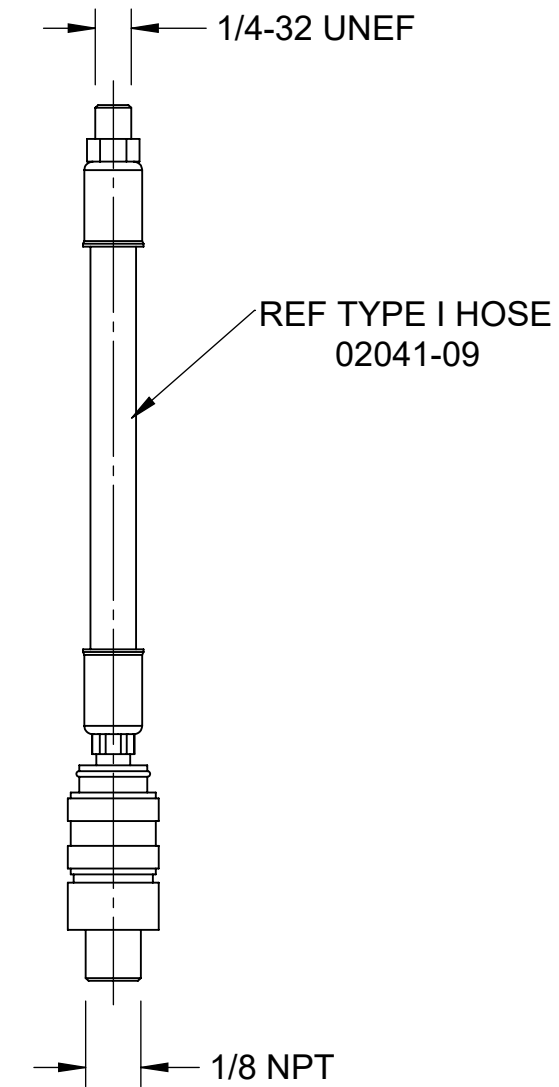
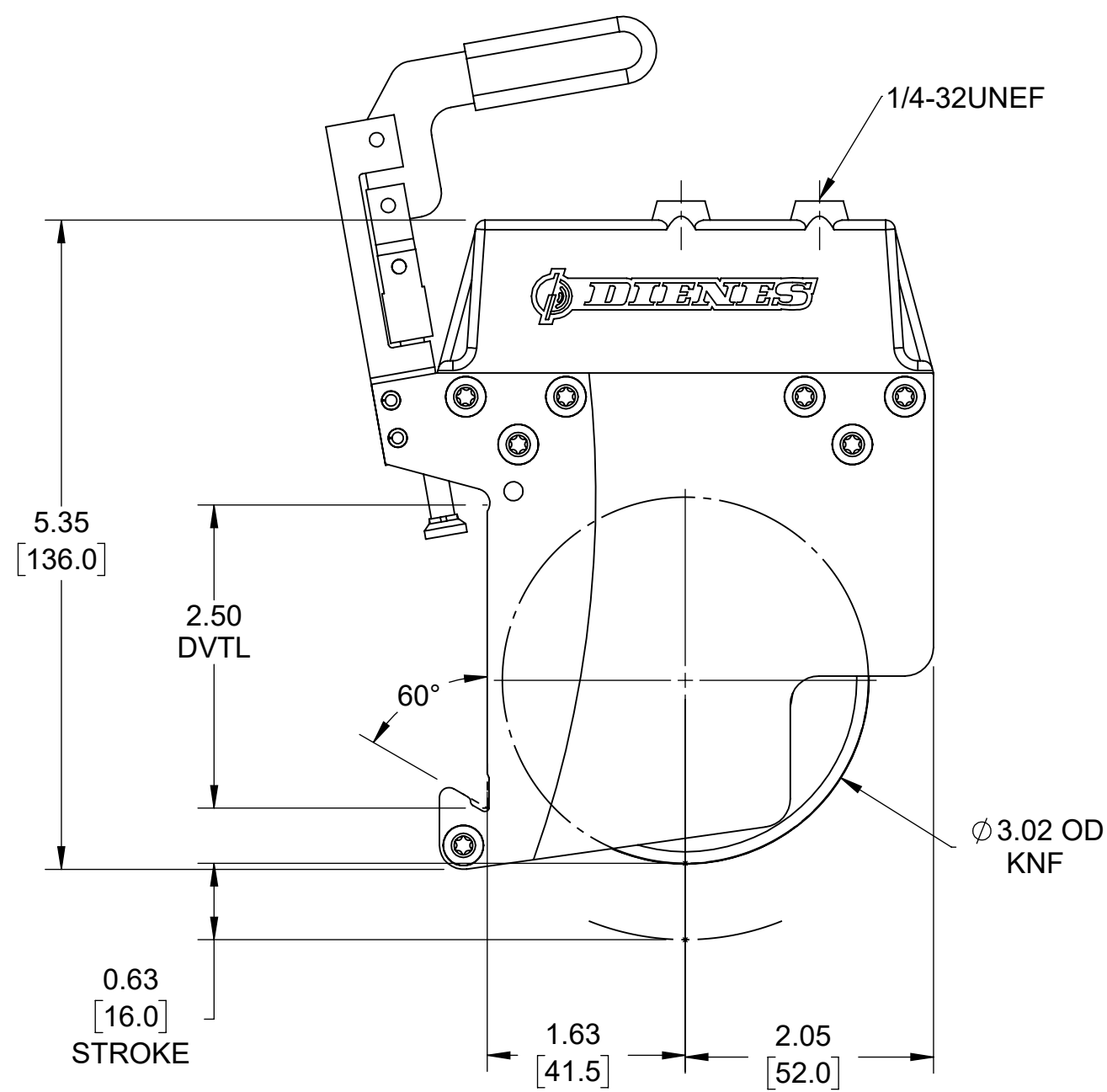
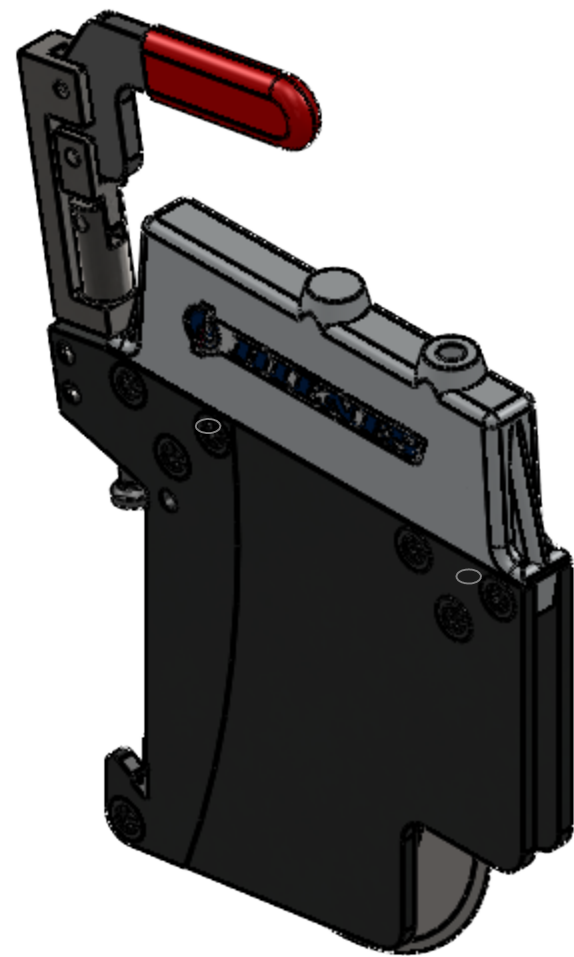

NOTES:

1. MATERIAL: SEE BILL OF MATERIAL.
2. THIS HOLDER IS STANDARD CONFIGURATION.
3. USE FIXTURE TO ENSURE HOLDER IS ASSEMBLED SQUARE, IF APPLICABLE
4. TEST HOLDER FOR STROKE & PNEUMATIC LEAKS.
5. APPROX. WEIGHT: 2.02 LBS
6. THIS DRAWING IS FOR REFERENCE ONLY, FOR OFFICIAL DRAWING SEE 244A220B01001

This document is the property of
Dienes Corporation
It may contain proprietary information
DO NOT USE FOR PURPOSES
OTHER THAN THOSE INTENDED

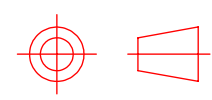
 US PROJECTION		DIENES CORPORATION <i>Spencer Massachusetts</i>	
REFERENCE METRIC DATA		HLDR,PQAS 1/2",W/QC STD	
<small>Unless Otherwise Noted Dimensions Are In Inches Tolerances Unless Noted:</small>		<small>Drawn by:</small>	BGB
<small>.XXX ±.005 .XX ±.010 FRACT. ±.015 ANGLE ±1/2° Finish Unless Noted: ✓</small>		<small>Date:</small>	05/14/2020
<small>DO NOT SCALE DRAWING</small>		<small>Checked by:</small>	BGB
<small>Sheet 1 of 2</small>		<small>Date:</small>	05/14/2020
<small>REF DWG: 02023-01</small>		<small>Scale:</small>	3:4
<small>Drawing Number</small>		C22300	
<small>Rev.</small>		A	
<small>For Internal DIENES CORPORATION Use Only</small>			

PQAS 1/2" Quick Clamp Score Cut Holder

Dienes No. 22300

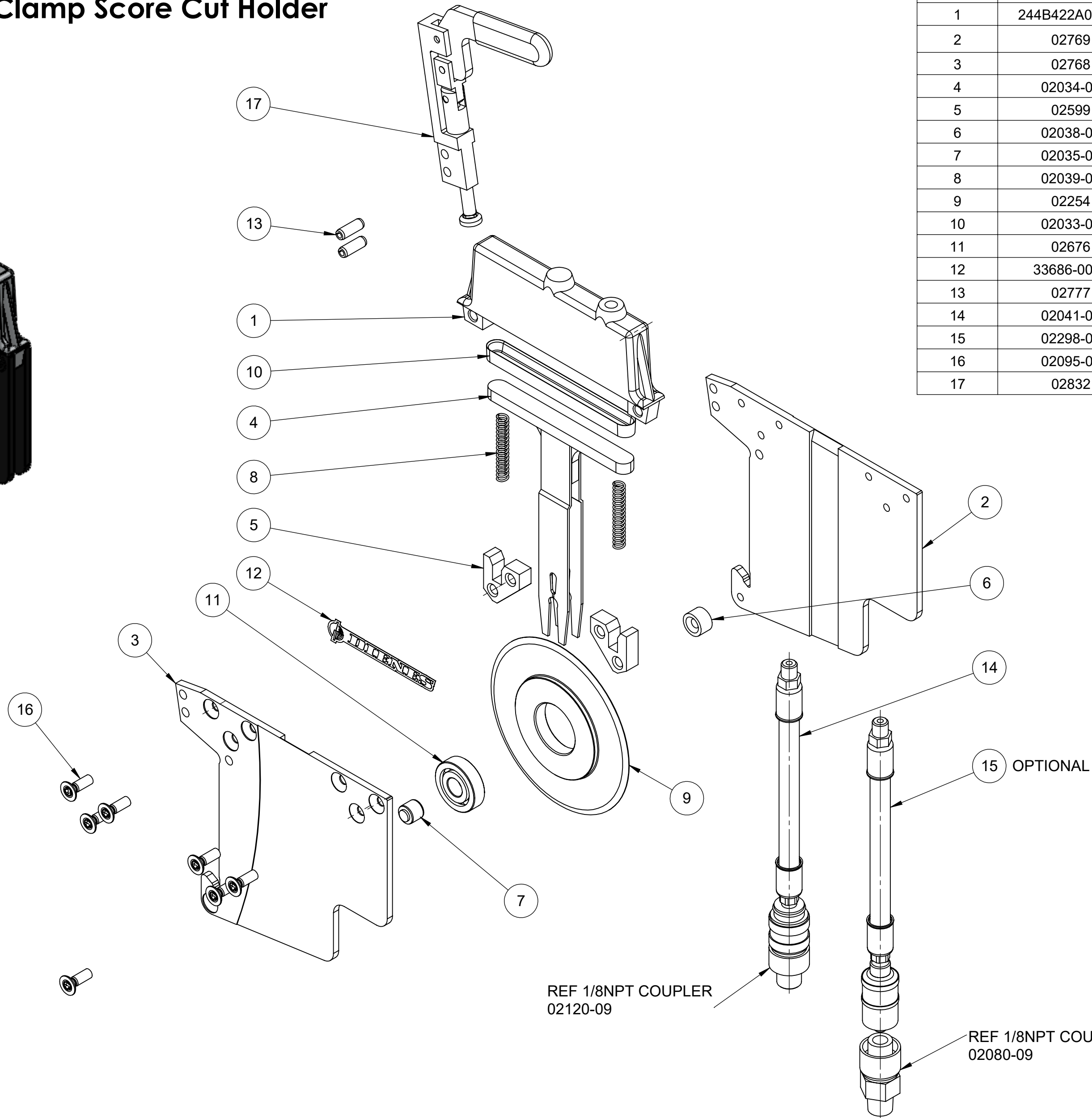
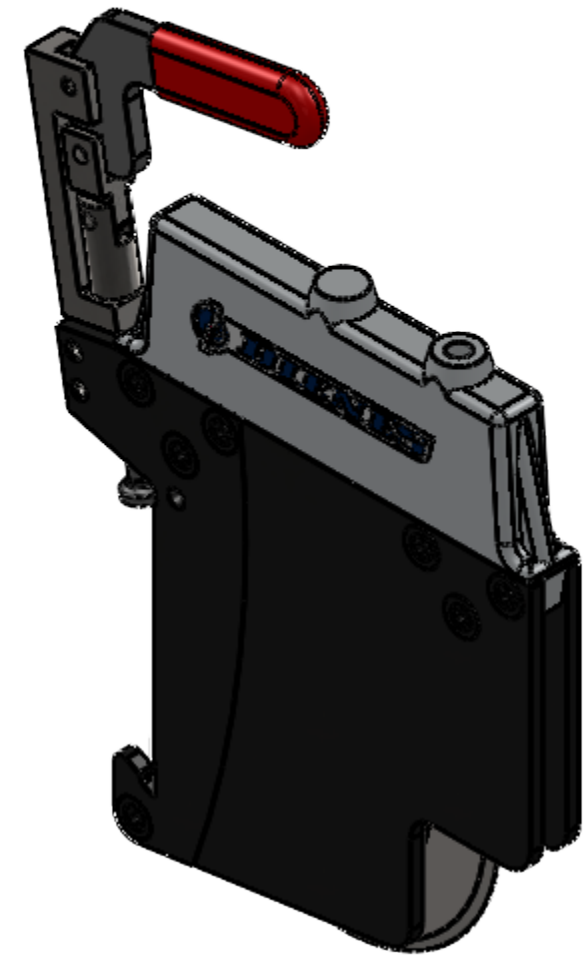

ITEM NO.	PART NUMBER	DESCRIPTION	
1	244B422A01001	PQAS PRESSURE CYLINDER	1
2	02769	PQAS LH SIDEPLATE (THRD)	1
3	02768	PQAS RH SIDEPLATE (C'SINK)	1
4	02034-09	PQAS 1/2" KNIFE FORK	1
5	02599	INTERMEDIATE PIECE	2
6	02038-09	DISTANCE RING	1
7	02035-09	BEARING PIN	1
8	02039-09	SPRG,PRESSURE,30mm LONG	2
9	02254	KNF,CRUSHCUT 793A - 52100	1
10	02033-09	GASKET,BLADDER PQAS 1/2"	1
11	02676	BRG,BALL,OPEN 8X22X6	1
12	33686-0015	LOGO,DECAL	1
13	02777	PIN,SPRING M4X12	2
14	02041-09	HOSE,AIR,TYPE 1 - 20" W/CPLR	1
15	02298-09	HOSE,AIR,TYPE 3, 20"W/CPLR	1
16	02095-09	SCR,CAP,FL TORX HD,M4X12	7
17	02832	QUICK CLAMP FOR PQAS 1/2"	1

REF 1/8NPT COUPLER
02120-09

REF 1/8NPT COUPLER
02080-09

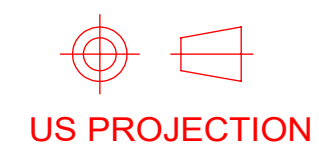

US PROJECTION

REFERENCE METRIC DATA

DIM	TOL
O.D.	
I.D.	
THK.	
REF DWG:	02023-01

DIENES CORPORATION
Spencer Massachusetts

HLDR,PQAS 1/2",W/QC STD

Unless Otherwise Noted Dimensions Are In Inches	Drawn by:	BGB
Tolerances Unless Noted:	Date:	05/14/2020
.XXX ±.005	Checked by:	BGB
.XX ±.010	Date:	05/14/2020
FRACT. ±.015	Scale:	3:4
ANGLE ±1/2°	Finish Unless Noted: <input checked="" type="checkbox"/> 125	
DO NOT SCALE DRAWING	Drawing Number	C22300
Sheet 2 of 2	Rev.	A

This document is the property of
Dienes Corporation
It may contain proprietary information
DO NOT USE FOR PURPOSES
OTHER THAN THOSE INTENDED

For Internal DIENES CORPORATION Use Only