

021086	-1.00 EA	CLAMP BODY, PQAS 3/8"(8-32)
021087	-1.00 EA	CLAMP ARM,PQAS 3/8"
02154-09	-1.00 EA	SCR,FILLISTER HD, 8-32X1.5
0010 02022-01	1.00 EA	HLDR,PQAS3/8",SCR,STD
0020 021259	1.00 EA	QUICK CLAMP FOR PQAS 3/8"
0030 655384	2.00 EA	PIN,TENSION 5/32 x 3/8 FS

REVISIONS			
REV.	ERN	DATE	CHC'D BY
-	4499	5/27/2020	RELSD

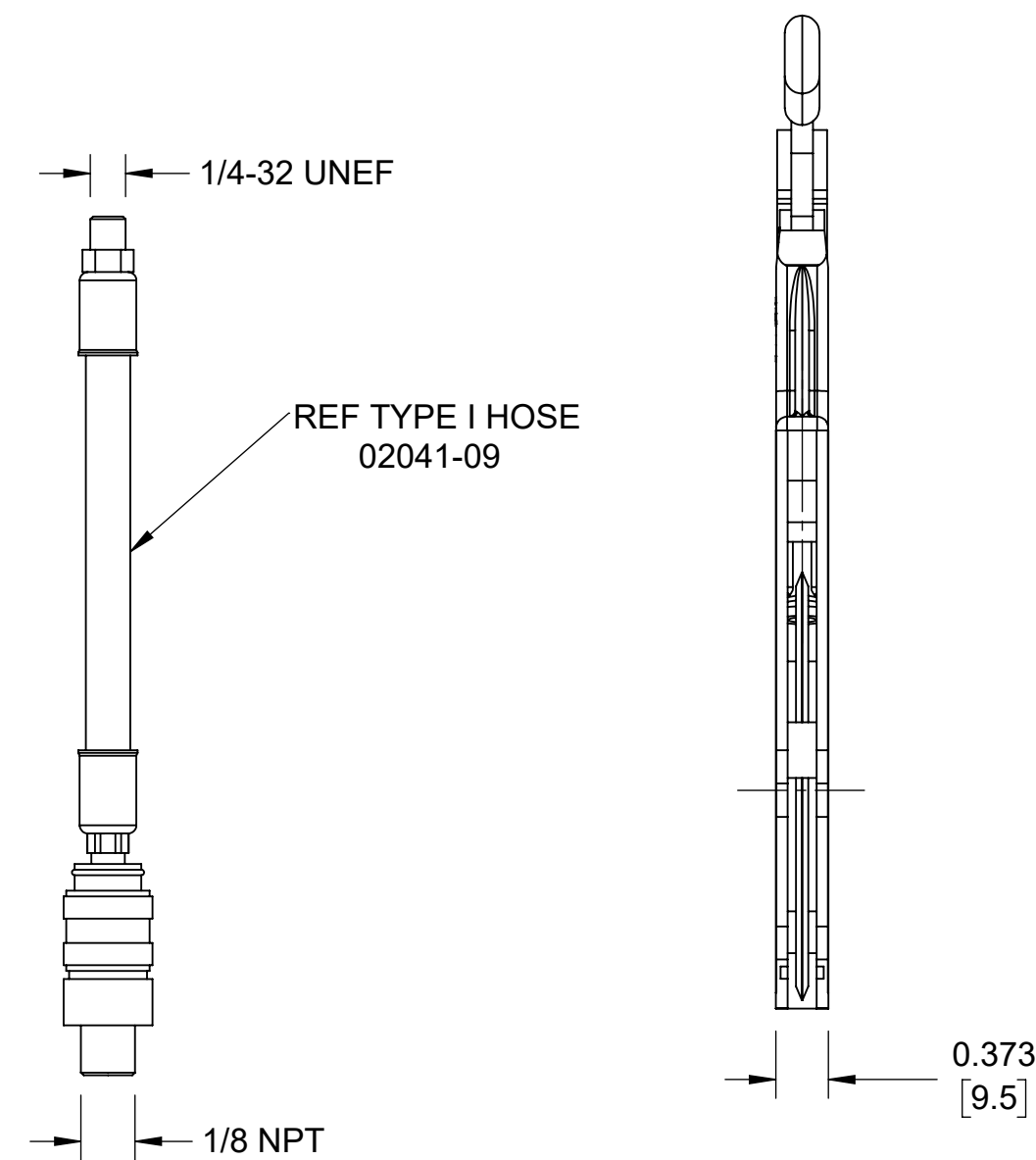
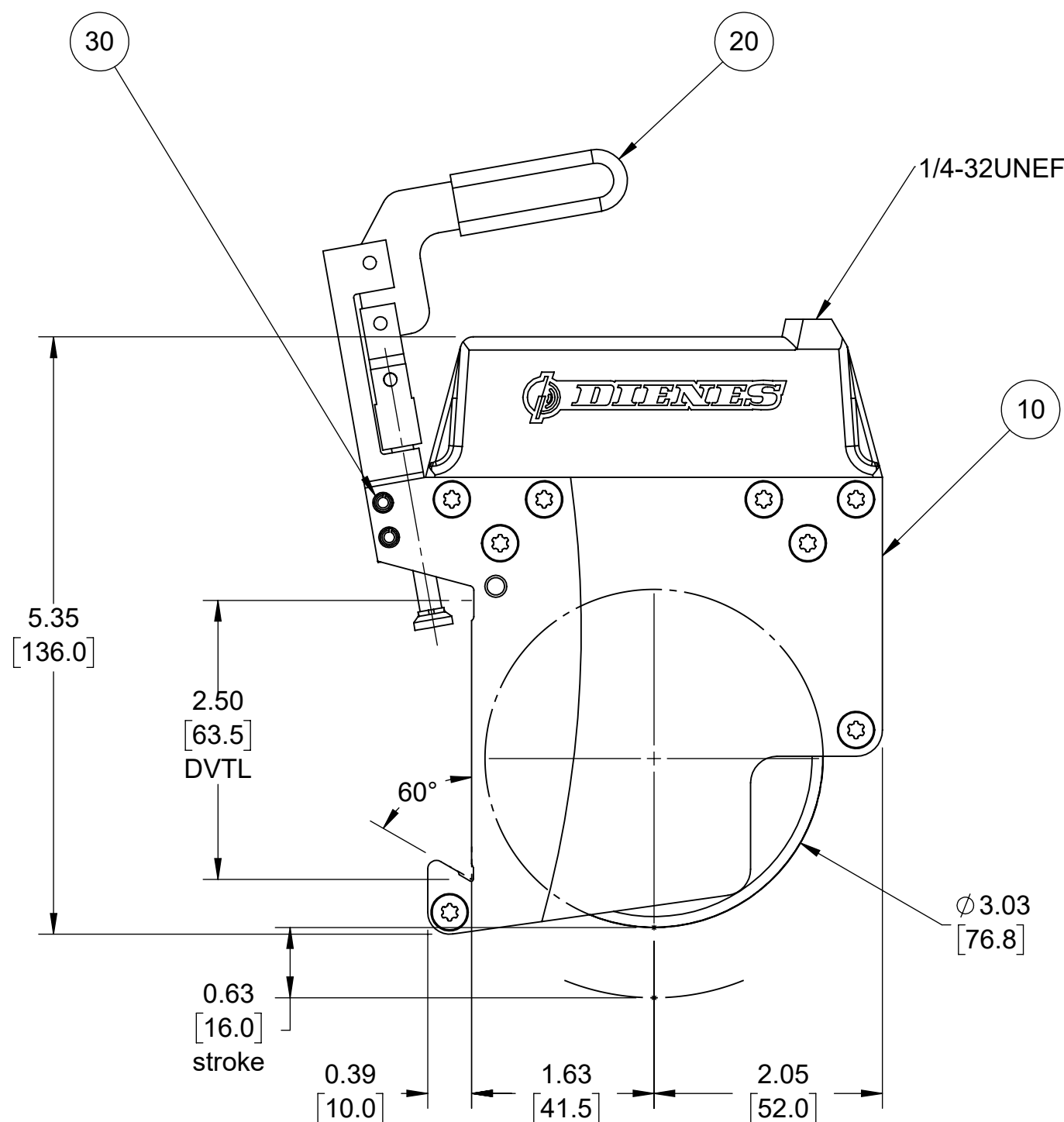
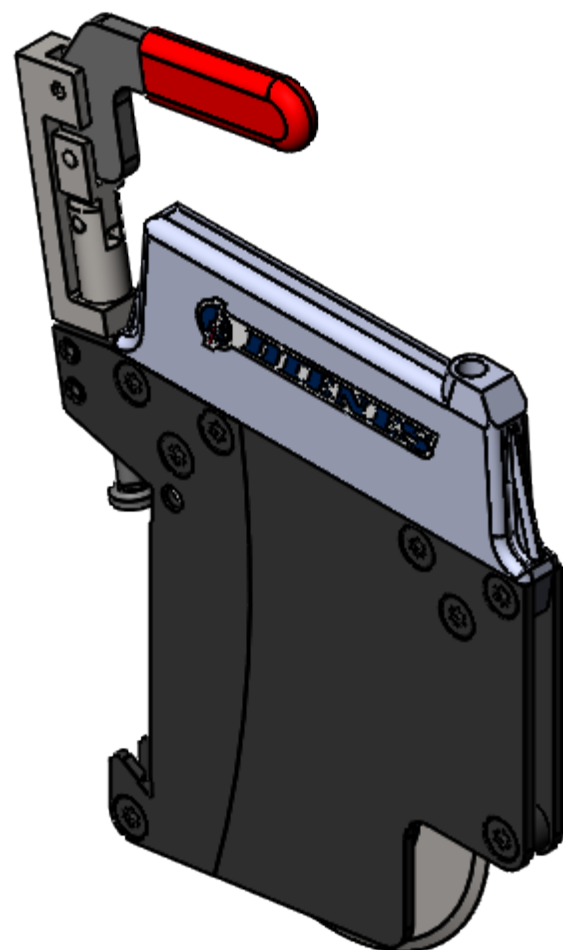

**NOTES:**

1. MATERIAL: SEE BILL OF MATERIAL.
2. THIS HOLDER IS STANDARD CONFIGURATION.
3. USE FIXTURE TO ENSURE HOLDER IS ASSEMBLED SQUARE, IF APPLICABLE
4. TEST HOLDER FOR STROKE & PNEUMATIC LEAKS.
5. APPROX. WEIGHT: 1.37 LBS

This document is the property of  
**Dienes Corporation**  
 It may contain proprietary information  
 DO NOT USE FOR PURPOSES  
 OTHER THAN THOSE INTENDED

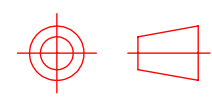
 US PROJECTION		<b>DIENES CORPORATION</b> Spencer Massachusetts	
REFERENCE METRIC DATA		<b>HLDR,PQAS,3/8 W/QC</b>	
Unless Otherwise Noted Dimensions Are In Inches		Drawn by:	BGB
Tolerances Unless Noted: .XXX ±.005 .XX ±.010 FRACT. ±.015 ANGLE ±1/2° Finish Unless Noted: ✓		Date:	05/27/2020
DO NOT SCALE DRAWING		Checked by:	BB
Sheet 1 of 2		Date:	05/27/2020
Drawing Number <b>C22430</b>		Scale:	3:4
REF DWG: 02022-01		Rev.	-
For Internal DIENES CORPORATION Use Only			

# PQAS 3/8" Quick Clamp Score Cut Holder

## Dienes No. 22430

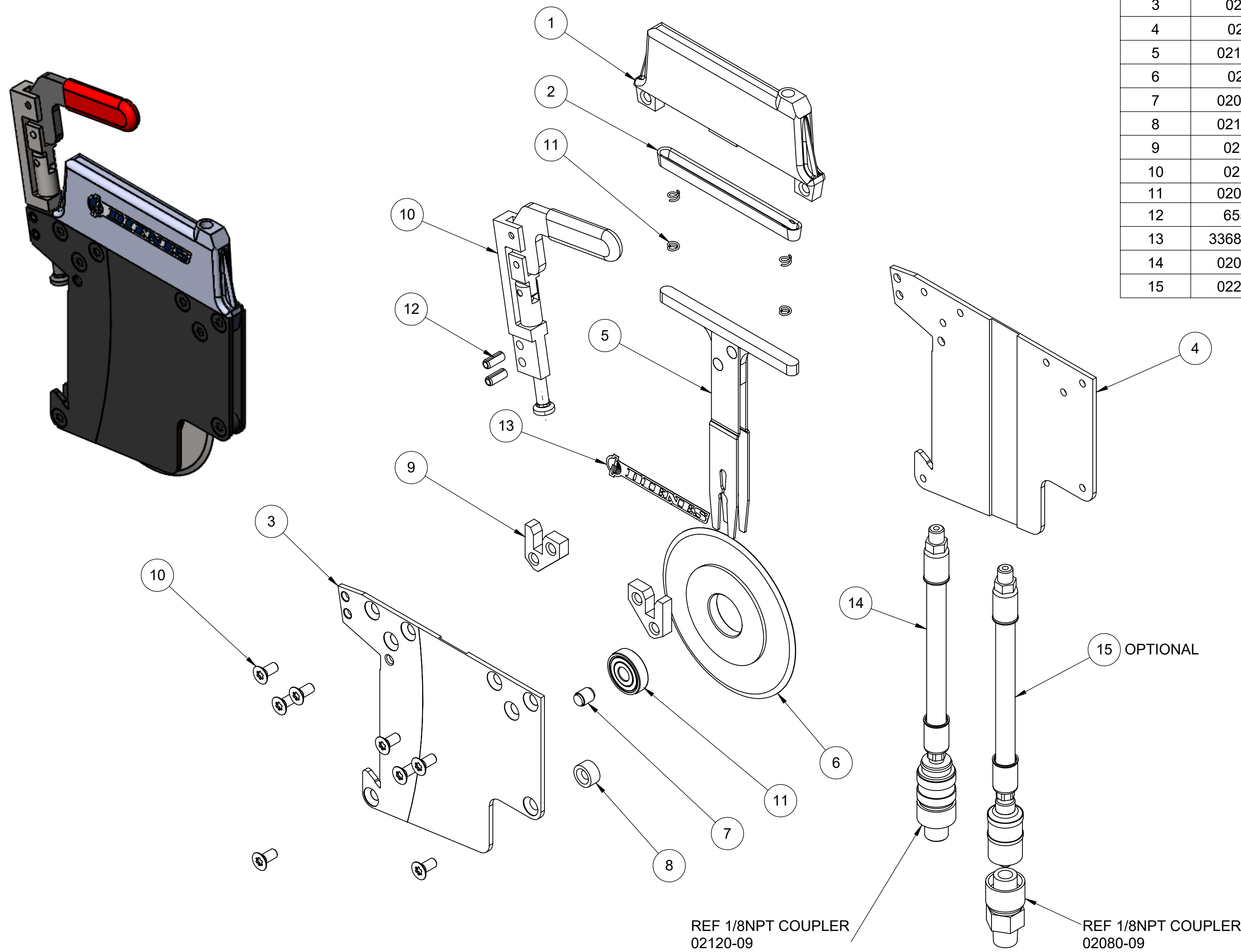

ITEM NO.	PART NUMBER	DESCRIPTION	QTY.
1	02152-09	CYLINDER,PRESSURE-PQAS 3/8	1
2	02042-09	GASKET,PQAS 3/8	1
3	02768	SIDEPLATE,RH (NON-REPLACEABLE)	1
4	02769	SIDEPLATE,LH (NON-REPLACEABLE)	1
5	02153-09	KNIFE FORK	1
6	02731	KNF,SCORE 3.0X.74X.204-45° 52	1
7	02043-09	PIN,BRG 3/8"	1
8	02133-09	DISTANCE RING,PQAS 3/8"	2
9	021208	INTERMEDIATE PIECE,PQAS 3/8"	2
10	021259	QUICK CLAMP FOR PQAS 3/8"	2
11	02039-09	SPRG,PRESSURE	1
12	655384	PIN,TENSION,5/32X3/8	2
13	33686-0015	LOGO,DECAL	1
14	02041-09	HOSE,AIR,TYPE 1 - 20" W/CPLR	1
15	02298-09	HOSE,AIR,TYPE 3 - 20" W/CPLR	1

This document is the property of  
**Dienes Corporation**  
 It may contain proprietary information  
 DO NOT USE FOR PURPOSES  
 OTHER THAN THOSE INTENDED

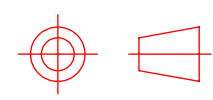
 US PROJECTION		<b>DIENES CORPORATION</b> <i>Spencer Massachusetts</i>	
<b>HLDR,PQAS,3/8 W/QC</b>		Drawing Number <b>C22430</b>	
<b>REFERENCE METRIC DATA</b>		Unless Otherwise Noted Dimensions Are In Inches Tolerances Unless Noted: .XXX ±.005 .XX ±.010 FRACT. ±.015 ANGLE ±1/2° Finish Unless Noted: <input checked="" type="checkbox"/> 125	Drawn by: <b>BGB</b> Date: <b>05/27/2020</b> Checked by: <b>BB</b> Date: <b>05/27/2020</b> Scale: 3:4
O.D.		DO NOT SCALE DRAWING	Rev. <b>-</b>
I.D.		Sheet <b>2</b> of <b>2</b>	
THK.			
REF DWG:		For Internal DIENES CORPORATION Use Only	