

0010	416450-01	1.00	EA	BODY ASSY-PQADF30 W/ADPT(STD)
0020	413361	1.00	EA	ASSY,KNF,HEAD,PQADF30
0030	651246	4.00	EA	SCR,CAP,LO SOC HD,M6X16 ZN FS
0040	244A112001001	1.00	EA	HOSE AIR,TYPE 1,M6, W/CPLR,20"

REVISIONS			
REV.	ERN	DATE	CHK'D BY
A		11/23/03	ELP
B	4499	1/20/2021	BGB

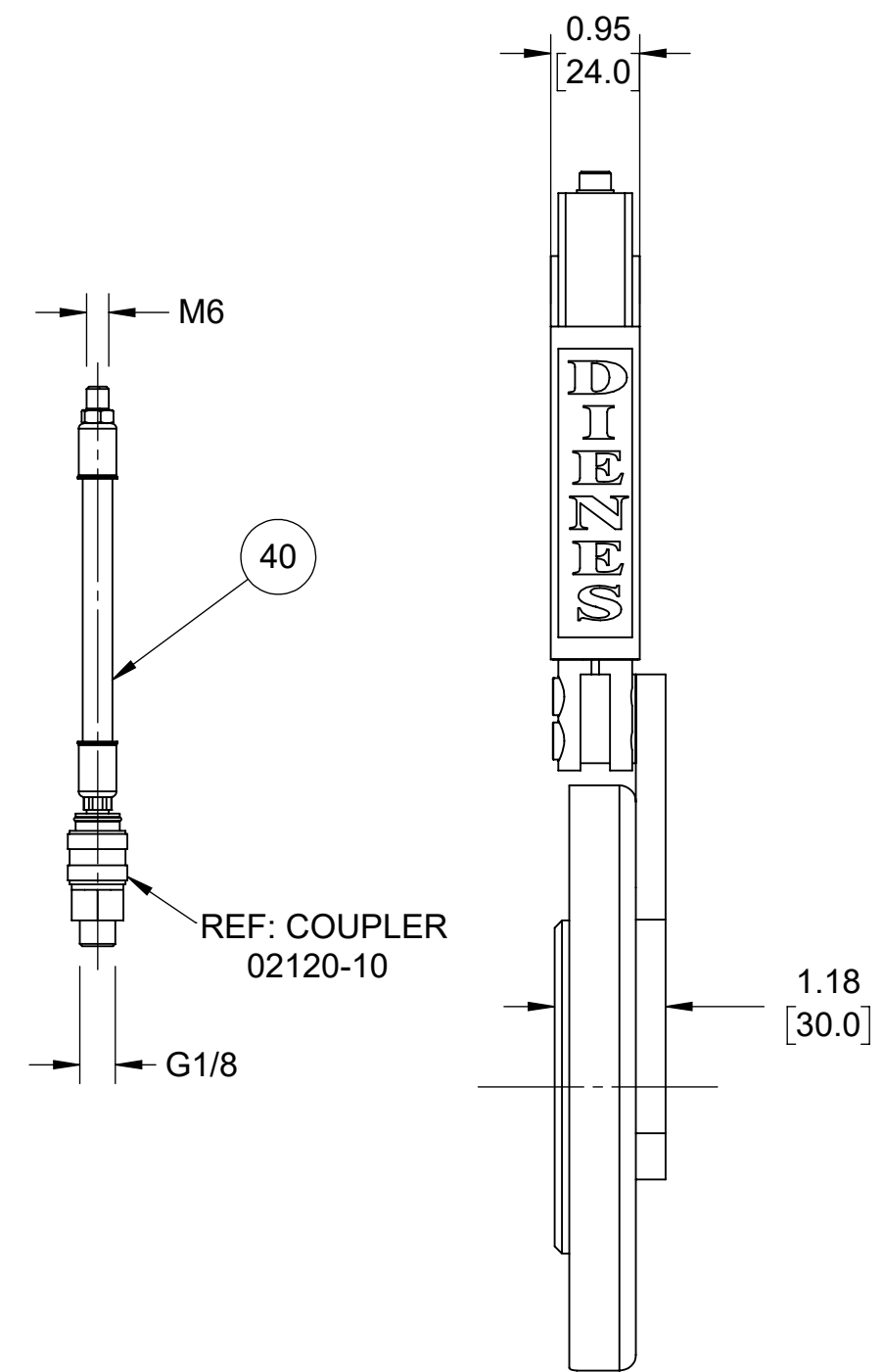
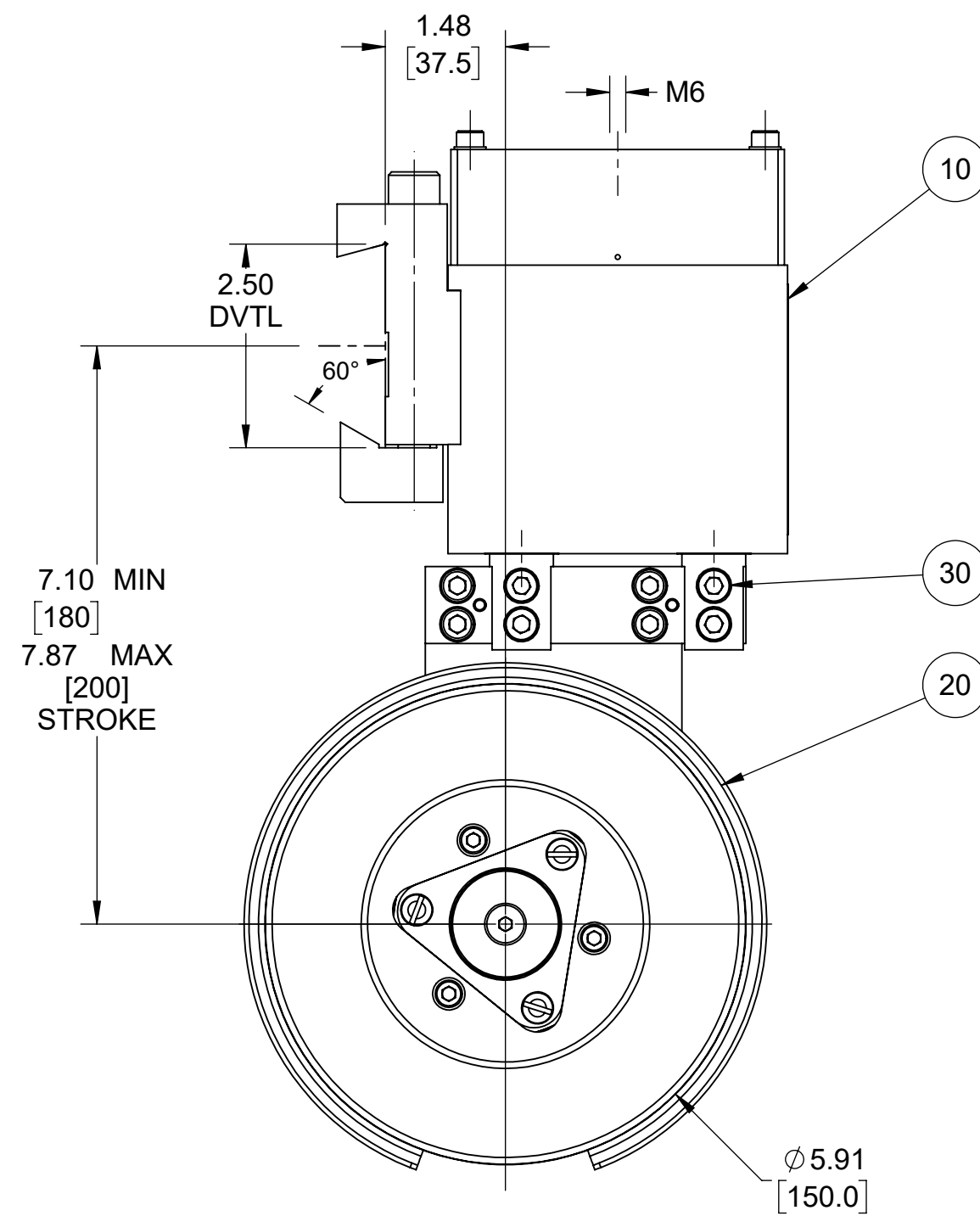
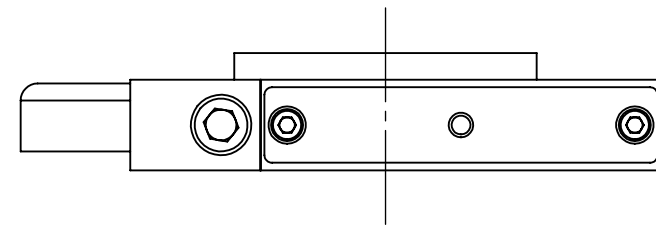
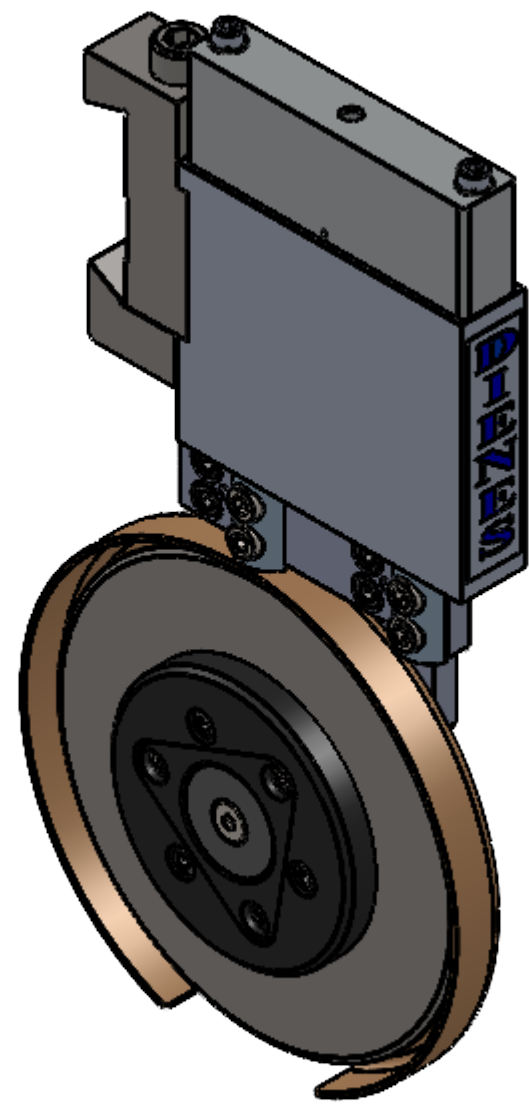

NOTES:

1. MATERIAL: SEE BILL OF MATERIAL.
2. THIS HOLDER IS STANDARD CONFIGURATION.
3. USE FIXTURE TO ENSURE HOLDER IS ASSEMBLED SQUARE, IF APPLICABLE
4. TEST HOLDER FOR STROKE & PNEUMATIC LEAKS.
5. APPROX. WEIGHT: 8.10 LBS

ⓑ
 CREATED DRAWING FROM SOLID MODEL
 IN SOLIDWORKS TO MADE SHEET 2 OF 2.

This document is the property of
Dienes Corporation
 It may contain proprietary information
 DO NOT USE FOR PURPOSES
 OTHER THAN THOSE INTENDED

 US PROJECTION		DIENES CORPORATION <i>Spencer Massachusetts</i> HLDR,PQADF30 STD									
REFERENCE METRIC DATA <table border="1"> <thead> <tr> <th>DIM</th> <th>TOL</th> </tr> </thead> <tbody> <tr> <td>O.D.</td> <td></td> </tr> <tr> <td>I.D.</td> <td></td> </tr> <tr> <td>THK.</td> <td></td> </tr> </tbody> </table>		DIM	TOL	O.D.		I.D.		THK.		Unless Otherwise Noted Dims in Inches Tolerances Unless Noted: .XXXX ±.0005 .XXX ±.005 .XX ±.010 .X ±.015 ANGLE ±1/2° Finish Unless Noted: <input checked="" type="checkbox"/> 125 DO NOT SCALE DRAWING Sheet <u>1</u> of <u>2</u>	Drawn by: BGB Date: 01/20/2021 Checked by: BB Date: 01/20/2021 Scale: 1:2 Drawing Number C413360 Rev. B
DIM	TOL										
O.D.											
I.D.											
THK.											
REF DWG: P2100-0002		For Internal DIENES CORPORATION Use Only									

PQADF30 Screw Clamp Score Cut Holder

Dienes No. 413360

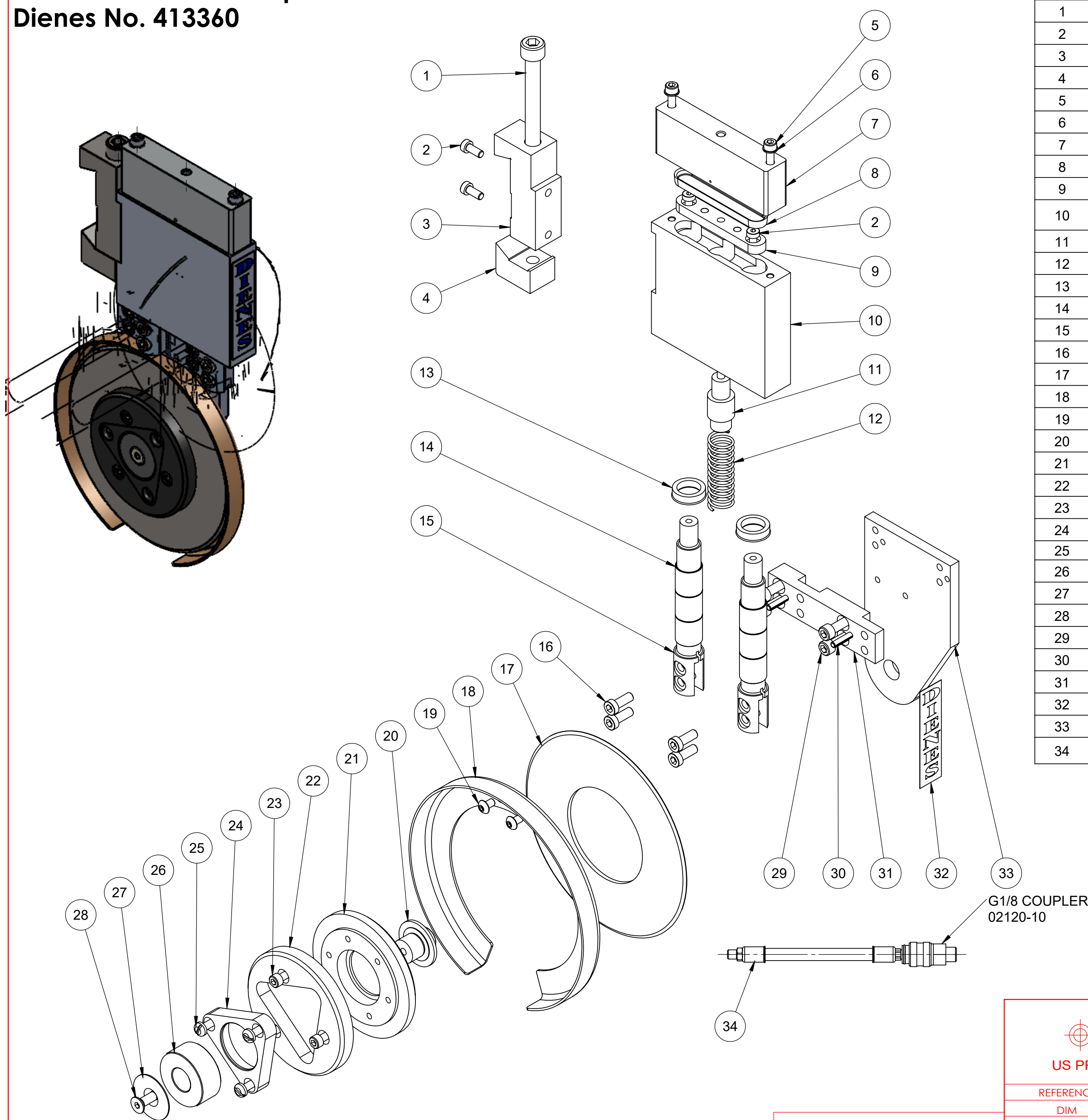

ITEM NO.	PART NUMBER	DESCRIPTION	QTY.
1	613760	SCR,CAP,SOC HD,M10X90	1
2	617166	SCR,CAP,LO SOC HD,M5X12	4
3	022086	PQA-DF-30 ADAPTER BODY	1
4	022156	PQA-DF-30 DOVETAIL CLAMP	1
5	613582	SCR,CAP,SOC HD,M5X45	2
6	615722	WASH,PLAIN,M5 FS	2
7	244B110563	CYLINDER,PRESSURE,PQADF30	1
8	244B090176010	GASKET,DF30	1
9	022160	PISTON	1
10	022159-10	BODY,HLDR,PQADF30,SINGLE SPRG	1
11	245C020966010	STUD,DEPTH ADJ.	1
12	0FFEDER018002	SPRG,COMP,0.7X,4.33"LG	1
13	650978	WIPER,DIRT-PU75	2
14	650973	BRG,DU-SELF LUBRICATING	6
15	243B020285010	GUIDE SHAFT,DF30	2
16	651246	SCR,CAP,LO SOC HD,M6X16,ZN	4
17	22020	KNF,SCORE 150X70X2.8 - 52100	1
18	245B000594080	GUARD,HAND,DF30	1
19	613390	SCR,CAP,BTN HD,M5X8	2
20	411330	AXLE-DF30	1
21	412493	KNIFE,CARRIER PQADF30	1
22	412494	COVER,OUTER PQADF30	1
23	613562	SCR,CAP,SOC HD,M5X12	3
24	412498	COVER,INNER RACE PQADF30	1
25	614280	SCR,MACH,PAN HD,M5X12	3
26	650979	BRG,ANG CONT 40X17X17.5	1
27	243B040287030	COVER,INNER,DF30	1
28	614144	SCR,CAP,FL SOC HD,M6X16	1
29	613620	SCR,CAP,SOC HD,M6X16 FS	4
30	650981	PIN,TENSION,M4X20	2
31	243B100288010	INTERIM PIECE-DF30	1
32	22056	NAME PLATE,DIENES LOGO	1
33	243B140289010	BRKT PLATE,HLDR,DF30	1
34	244A112001001	HOSE AIR,TYPE 1,M6, W/CPLR,20"	

G1/8 COUPLER
02120-10

This document is the property of
Dienes Corporation
It may contain proprietary information
DO NOT USE FOR PURPOSES
OTHER THAN THOSE INTENDED

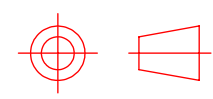
 US PROJECTION		DIENES CORPORATION <i>Spencer Massachusetts</i>	
REFERENCE METRIC DATA		HLDR,PQADF30 STD	
<small>Unless Otherwise Noted Dims in Inches</small>		<small>Drawn by:</small>	BGB
<small>Tolerances Unless Noted:</small> .XXX ±.0005 XXX ±.005 XX ±.010 XX ±.015 ANGLE ±1/2° Finish Unless Noted: <input checked="" type="checkbox"/> 125		<small>Date:</small>	01/20/2021
<small>DO NOT SCALE DRAWING</small>		<small>Checked by:</small>	BB
<small>Sheet 2 of 2</small>		<small>Date:</small>	01/20/2021
<small>Scale:</small>		<small>Scale:</small>	1:2
<small>REF DWG:</small>		<small>Drawing Number</small>	C413360
		<small>Rev.</small>	-
<small>For Internal DIENES CORPORATION Use Only</small>			